

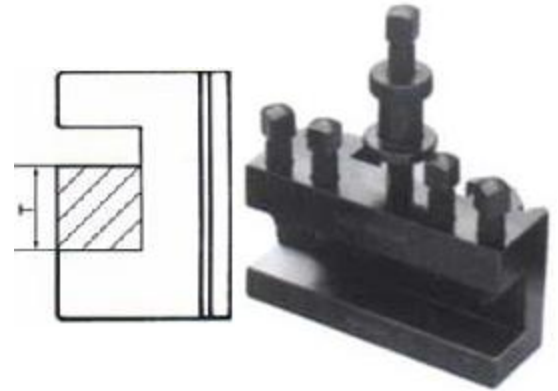

TOOLHOLDER TOOL BITS

MODEL NO.	Max Square and Rectangular Tools T (mm)	MODEL NO.	Max Square and Rectangular Tools T (mm)
502-M	16	502-BR-BP	25
502-AR-AP	16	502-B	32
502-A	20	502-C	32
ii	ii	502-D	40



TOOLHOLDER FOR ROUND SHANKS

MODEL NO.	Max Holding Dia. (mm)	MODEL NO.	Max Holding Dia. (mm)
503-M	14	503-BR-BP	20
503-AR-AP	16	503-B	24
503-A	18	503-C	26
ii	ii	503-D	35

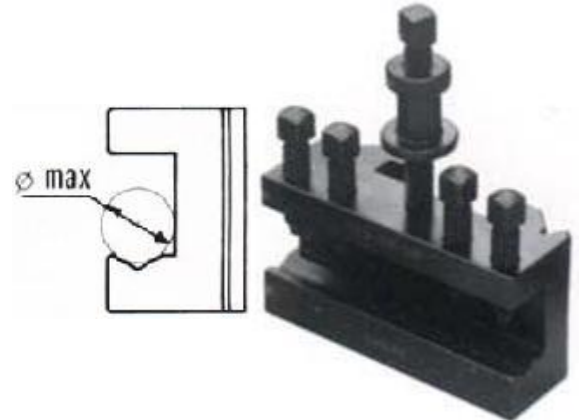

TOOLHOLDER MORSE TAPER SHANK

MODEL NO.	Max Holding Dia. (mm)	MODEL NO.	Max Holding Dia. (mm)
504-M	1MT	504-BR-BP	3MT
504-AR-AP	1MT	504-B	3MT
504-A	2MT	504-C	4MT
ii	ii	504-D	5MT

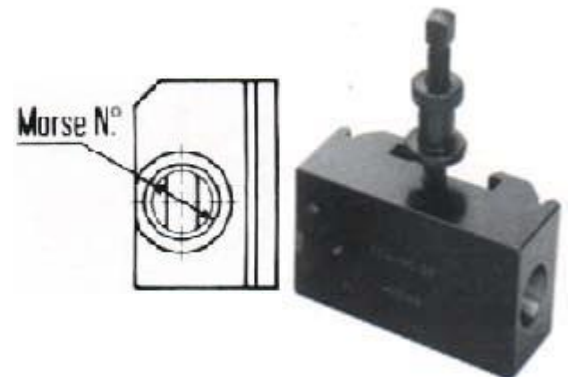

TOOLHOLDER FOR BORING BAR

MODEL NO.	Max Holding Dia.	MODEL NO.	Max Holding Dia.
540-M	18	540-BR-BP	32
540-AR-AP	20	540-B	40
540-A	25	540-C	50
ii	ii	540-D	60

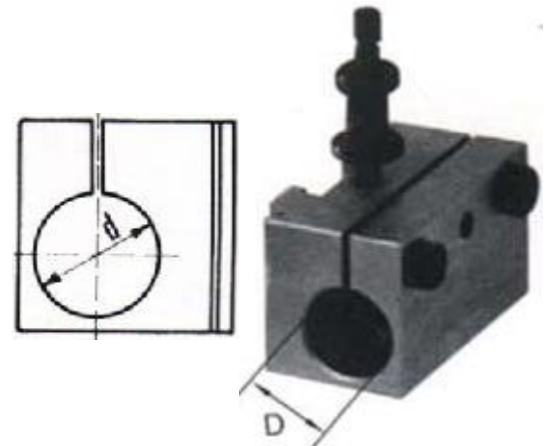

TOOLHOLDER FOR PARTING BLADES

MODEL NO.	Max Holding Dia. (mm)	MODEL NO.	Max Holding Dia. (mm)
550-M	15 <sub>±0.03</sub>	550-BR-BP	20 <sub>±0.05</sub>
550-AR-AP	18 <sub>±0.03</sub>	550-B	25 <sub>±0.05</sub>
550-A	20 <sub>±0.05</sub>	550-C	30 <sub>±0.05</sub>
ii	ii	550-D	35 <sub>±0.07</sub>

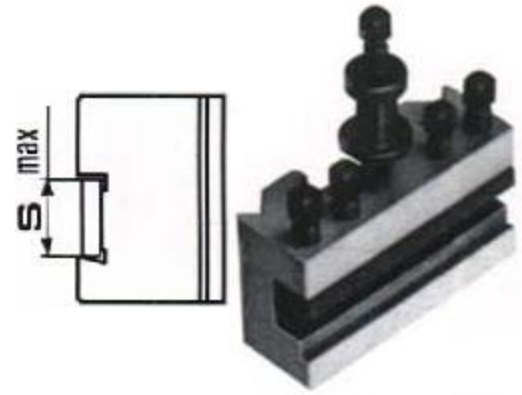

MODEL NO.	CH	MODEL NO.	L	MODEL NO.	L	MODEL NO.	μ
515-M	7	505-M	66	506-M	20	508-M	7
515-AR-AP	8	505-AR-AP	81	506-AR-AP	26	508-AR-AP	8
515-A	8	505-A	90	506-A	30	508-A	10
515-BR-BP	10	505-BR-BP	108	506-BR-BP	37	508-BR-BP	10
515-B	10	505-B	125	506-B	42	508-B	12
515-C	12	505-C	140.5	506-C	48	508-C	14
515-D	14	505-D	156	506-D	50	508-D	14

